

# **MIXPAC™ Systems for Adhesives**

## 2-Component Dispensers



Innovation in Application

# Overview

## Dispenser Systems

The Mixpac **DS Manual Dispenser**  
for 50 and 75mL BS-System Cartridges

**MIXPAC™**  
DS  
Manual  
Dispenser

The Mixpac **DM Manual Dispenser**  
for 200 and 400mL C and F-System Cartridges

**MIXPAC™**  
DM  
Manual  
Dispenser

The Mixpac **DMA/DMB Manual Dispenser**  
for 50 and 75mL A and B-System Cartridges

**MIXPAC™**  
DMA/DMB  
Manual  
Dispenser

The Mixpac **DP Pneumatic Dispenser**  
for 200 and 400mL C and F-System Cartridges

**MIXPAC™**  
DP  
Pneumatic  
Dispenser





## Table of Contents

MIXPAC™ DS .....	4
MIXPAC™ DMA/DMB .....	6
MIXPAC™ DM 200 .....	8
MIXPAC™ DM 400 .....	10
MIXPAC™ DP 200-70 .....	12
MIXPAC™ DP 400-85 .....	14
MIXPAC™ DP 400-100 .....	16
MIXPAC™ Accessories and Spare Parts .....	18







# MIXPAC™ 2-Component Dispenser

## MIXPAC™ DS

A manual dispenser for BS-System cartridges.

### Cartridge Support

Flap designed for maximum cartridge support and for easy cartridge exchange

### Plunger System

Easy to exchange

### Release Button

Easily accessible with one hand

### Trigger

Dual drive to ensure even high viscosity materials maintain their mixing ratio

### Ergonomic Handle

For maximum comfort



### Product advantages

- Designed specifically for Mixpac BS system cartridges
- High gearing ratio
- One-handed operation

### Customer benefits

- Easy cartridge positioning and fixation
- Swift and easy to use, clean application
- Ergonomic
- Can easily be converted into different ratios with proper plunger.
- Easily customized with customer print.

### Applications

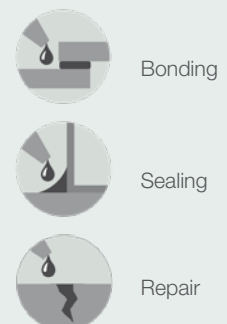

### Product by range



# The MIXPAC™ DS - designed to provide reliable 2-component dispensing.

## Specifications

- Weight 215g / 0.47lbs
- Length: 109mm / 4.3in
- Tool material: PPO & reinforced nylon
- Cartridge capacity: 50-75mL
- Cartridge ratio: 1:1/2:1/4:1/10:1

## Dimensions

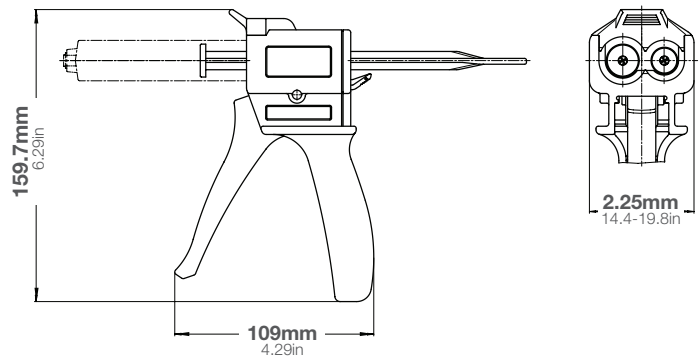

Part number:	Article number:	Ratio			
		1:1	2:1	4:1	10:1
DS 51-04-00	109146			✓	
DS 51-10-00	101929				✓
DS 53-01-00	101934	✓	✓		
DS 75-10-00	115676				✓
DS 77-01-00	110938	✓			

## Packaging:

Packed individually 64 units per master carton (50mL)  
Packed individually 32 units per master carton (75mL)

## Matching MIXPAC™ cartridges (BS-System)



50mL / 1:1  
PP/PA



50mL / 2:1  
PP



50mL / 4:1  
PP/PBT



50mL / 10:1  
PP/PBT



75mL / 1:1  
PP



75mL / 10:1  
PBT

## Other matching cartridges

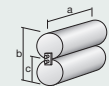

1:1	mm	inch
a	109	4.29
b	50	1.97
c	Ø 22	Ø 0.87

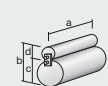

2:1	mm	inch
a	109	4.29
b	50	1.97
c	Ø 26	Ø 1.02
d	Ø 19	Ø 0.75

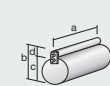

4:1	mm	inch
a	109	4.29
b	47	1.85
c	Ø 28	Ø 1.10
d	Ø 15	Ø 0.59

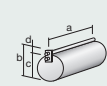

10:1	mm	inch
a	109	4.29
b	47	1.85
c	Ø 30	Ø 1.18
d	Ø 11	Ø 0.43

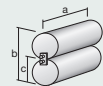

1:1	mm	inch
a	155	6.14
b	50	1.97
c	Ø 22	Ø 0.87

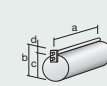

10:1	mm	inch
a	156	6.14
b	47	1.85
c	Ø 30	Ø 1.18
d	Ø 12	Ø 0.47

## Conversion kits

PLS 053-01, PLS 051-04, PLS 051-10, PLS 075-10,  
PLS 077-01, See page 18.

## Matching accessories

All accessories are displayed on page 18.



# MIXPAC™ 2-Component Dispenser

## MIXPAC™ DMA/DMB

A manual dispenser for A and B-System cartridges.

### Cartridge Support

Flap designed for maximum cartridge support and for easy cartridge exchange

### Plunger System

Easy to exchange



### Release Button

Easily accessible with one hand

### Trigger

Dual drive to ensure even high viscosity materials maintain their mixing ratio

Ergonomic Handle  
For maximum comfort

### Product advantages

- Designed specifically for Mixpac A and B system cartridges
- High gearing ratio
- One-handed operation

### Customer benefits

- Easy cartridge positioning and fixation
- Swift and easy to use, clean application
- Ergonomic
- Can easily be converted into all 50mL and 75mL A and B system ratios.
- Easily customized with customer print.

### Applications



Bonding



Sealing



Repair

### Product by range

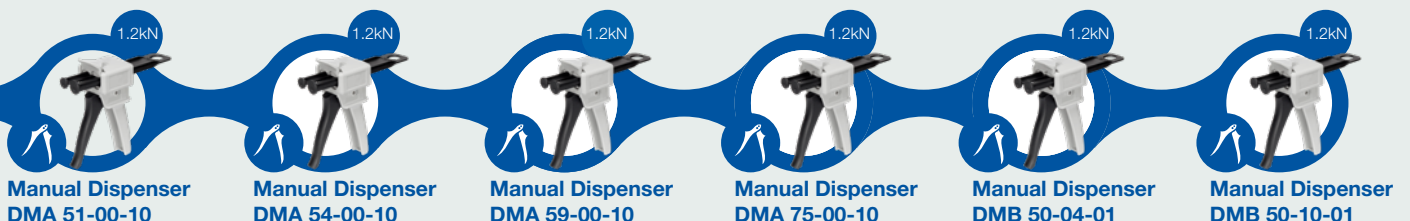

Manual Dispenser  
DMA 51-00-10

Manual Dispenser  
DMA 54-00-10

Manual Dispenser  
DMA 59-00-10

Manual Dispenser  
DMA 75-00-10

Manual Dispenser  
DMB 50-04-01

Manual Dispenser  
DMB 50-10-01

# The MIXPAC™ DMA/DMB - designed to provide reliable 2-component dispensing.

## Specifications

- Weight 184g / 0.41lbs
- Length: 109mm / 4.3in
- Tool material: PBT & reinforced nylon
- Cartridge capacity: 50/75mL
- Cartridge ratio: 1:1/2:1/4:1/10:1

Part number:	Article number:	Ratio			
		1:1	2:1	4:1	10:1
DMA 51-00-10	101875	✓	✓		
DMA 54-00-10	101883	✓	✓	✓	
DMA 59-00-10	112790	✓	✓		✓
DMA 75-00-10	111746	✓			
DMB 50-04-01	116795			✓	
DMB 50-10-01	116795				✓

## Dimensions

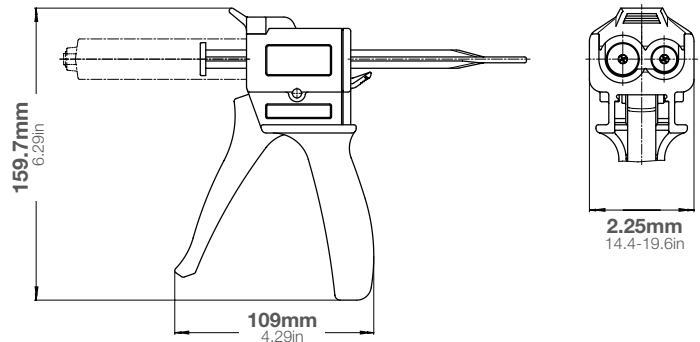

## Packaging:

Packed individually 64 units per master carton (50ml)  
Packed individually 32 units per master carton (75ml)

## Matching MIXPAC™ cartridges

### A-System



50mL / 1:1 PP/PA      50mL / 2:1 PP/PA      50mL / 4:1 PP/PA      50mL / 10:1 PP/PA/PBT      75mL / 1:1 PP

### B-System



50mL / 1:1 PP/PA      50mL / 2:1 PP      50mL / 4:1 PP/PBT      50mL / 10:1 PP/PBT

## Other matching cartridges

### A System

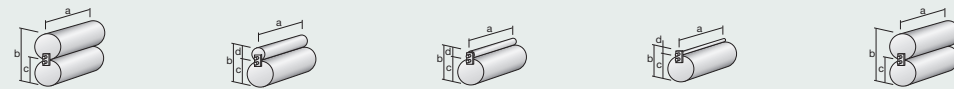

Ratio	mm	inch	Ratio	mm	inch	Ratio	mm	inch	Ratio	mm	inch	Ratio	mm	inch	
1:1	a	103	4.06	2:1	a	105	4.13	4:1	a	106	4.17	10:1	a	106	4.17
	b	46	1.81		b	46	1.81		b	46	1.81		b	46	1.81
	c	∅ 21	∅ 0.83		c	∅ 25	∅ 0.98		c	∅ 25	∅ 0.98		c	∅ 25	∅ 0.98
					d	∅ 18	∅ 0.71		d	∅ 13	∅ 0.51		d	∅ 9	∅ 0.35
													a	218	8.58
													b	46	1.81
													c	∅ 21	∅ 0.83

### B System

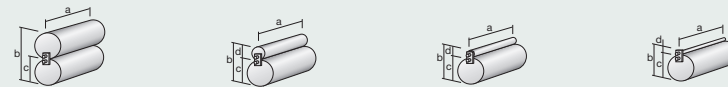

Ratio	mm	inch	Ratio	mm	inch	Ratio	mm	inch	Ratio	mm	inch				
1:1	a	107	4.21	2:1	a	106	4.17	4:1	a	127	5.00	10:1	a	128	5.04
	b	46	1.81		b	46	1.81		b	46	1.81		b	46	1.81
	c	∅ 22	∅ 0.87		c	∅ 25	∅ 0.98		c	∅ 25	∅ 0.98		c	∅ 25	∅ 0.98
					d	∅ 18	∅ 0.71		d	∅ 13	∅ 0.51		d	∅ 9	∅ 0.35

## Conversion kits

PLA 050-01, PLA 050-04, PLA 050-10, PLA 075-01, PLB 50-04, PLB 50-10, See page 18.

## Matching accessories

All accessories are displayed on page 18.



# MIXPAC™ 2-Component Dispenser

## MIXPAC™ DM 200

A manual dispenser for C and F-System cartridges.

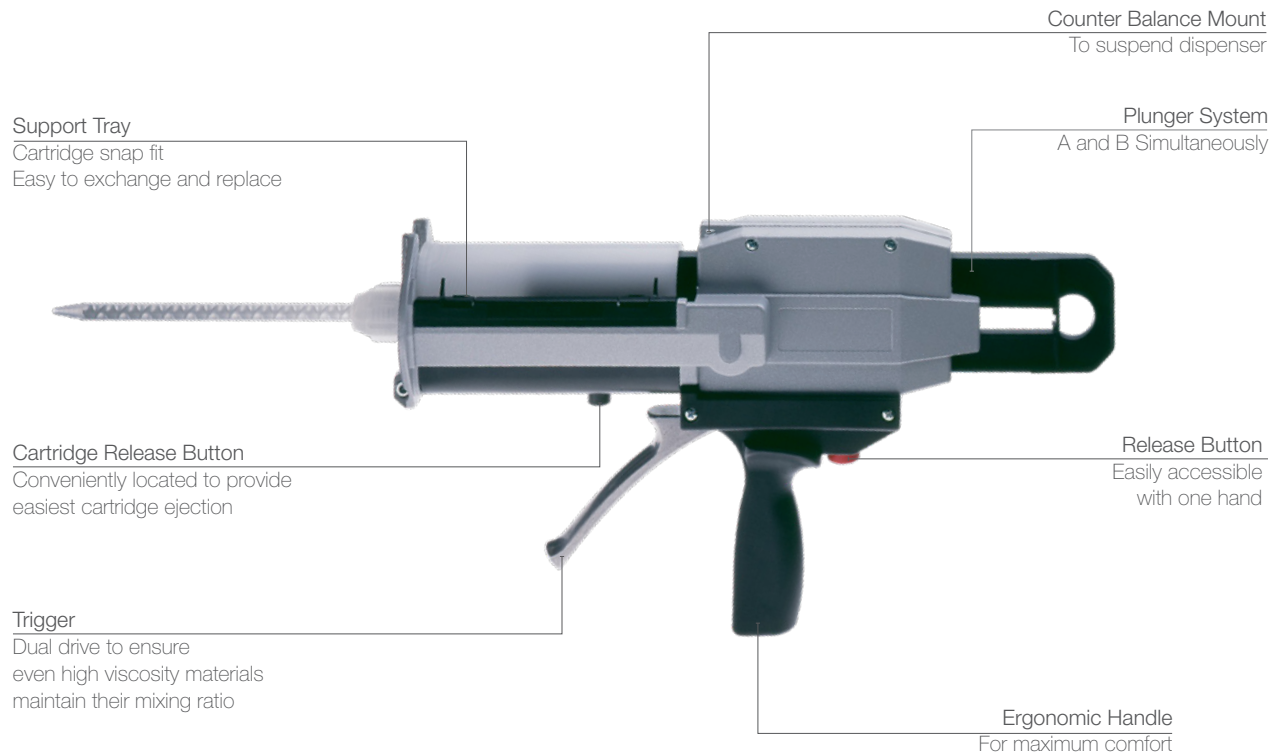

### Product advantages

- Designed specifically for Mixpac C and F System Cartridges
- Cartridge snap fit
- High gear ratio
- One-hand-operation
- Long-life technology

### Customer benefits

- Easy cartridge positioning and fixation
- Ergonomic
- High precision and dispensing accuracy
- Can easily be converted into different ratios with proper plunger.

### Applications

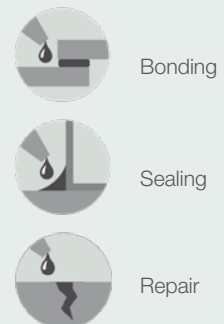

### Product by range





# The MIXPAC™ DM 200 - designed to provide reliable 2-component dispensing.

## Specifications

- Weight 1.35kg / 2.98lbs
- Length: 366mm / 14.4in
- Maximum Thrust: 5.2kN ( 520kg), 3.7mm stroke
- Tool material: cast aluminium and reinforced nylon
- Cartridge capacity: 200mL
- Cartridge ratio: 1:1/2:1/4:1/10:1

## Dimensions

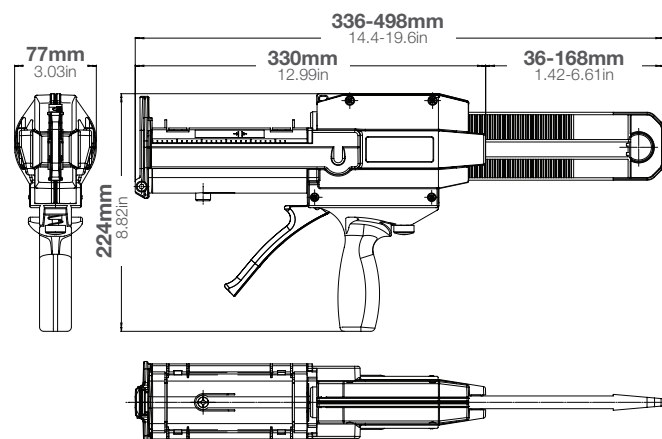

Part number:	Article number:	Ratio			
		1:1	2:1	4:1	10:1
DM 200-01	114413	✓	✓		
DM 200-04	114425			✓	
DM 200-10	114535				✓

## Packaging:

Packed individually 1 units per master carton

## Matching MIXPAC™ cartridges (C-System and F-System)



200mL / 1:1  
PP/PA



200mL / 2:1  
PP/PA



200mL / 4:1  
PP/PBT



200mL / 10:1  
PP/PBT

## Other matching cartridges

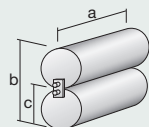

1:1	mm	inch
a	148	5.83
b	79	3.11
c	Ø 37	Ø 1.46

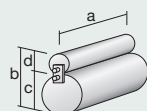

2:1	mm	inch
a	148	5.83
b	81	3.19
c	Ø 50	Ø 1.97
d	Ø 31	Ø 1.22

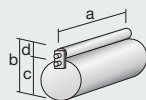

4:1	mm	inch
a	148	5.83
b	77	3.01
c	Ø 49	Ø 1.93
d	Ø 25	Ø 0.98

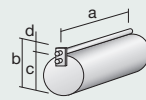

10:1	mm	inch
a	148	5.83
b	78	3.07
c	Ø 55	Ø 2.17
d	Ø 19	Ø 0.74

## Conversion kits

CK 200-01, CK 200-04, CK 200-10, See page 18.

## Matching accessories

All accessories are displayed on page 18.



# MIXPAC™ 2-Component Dispenser

## MIXPAC™ DM 400

A manual dispenser for C and F-System cartridges.

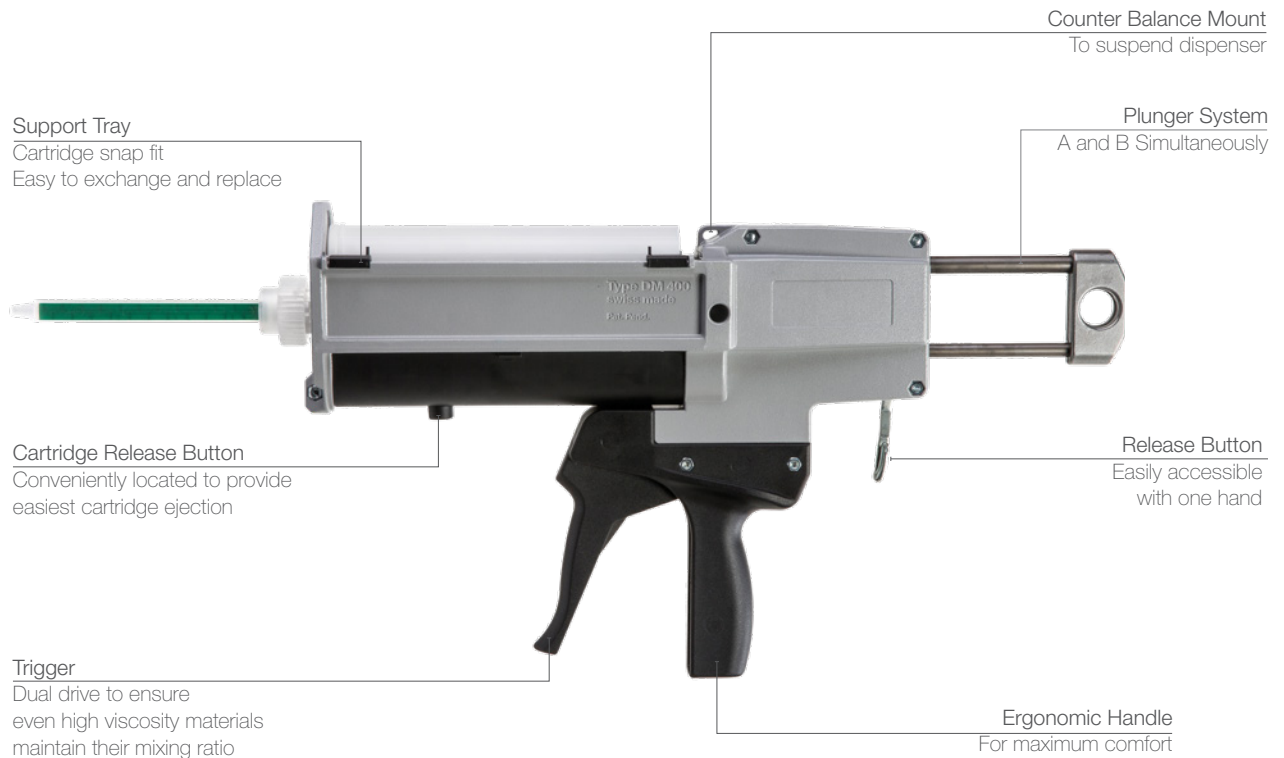

### Product advantages

- Designed specifically for Mixpac C and F System Cartridges
- Cartridge snap fit
- High gear ratio
- One-hand-operation
- Long-life technology

### Customer benefits

- Easy cartridge positioning and fixation
- Ergonomic
- High precision and dispensing accuracy
- Can easily be converted into all ratios with proper conversion kits.

### Applications

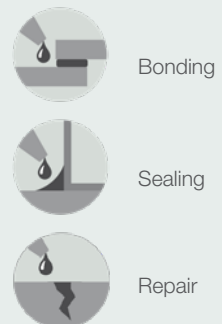

### Product by range



# The MIXPAC™ DM 400 - designed to provide reliable 2-component dispensing.

## Specifications

- Weight 1.85kg / 4.08lbs
- Length: 360mm / 14.2in
- Maximum Thrust: 6.4kN ( 640kg), 2.1mm stroke
- Tool material: cast aluminium and reinforced nylon
- Cartridge capacity: 400mL
- Cartridge ratio: 1:1/2:1/4:1/10:1

## Dimensions

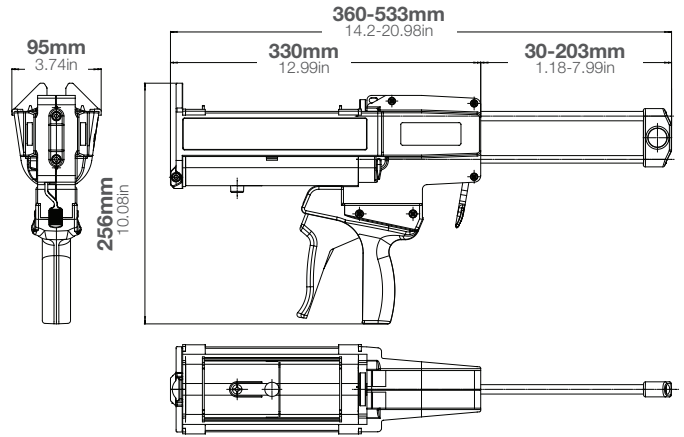

Part number:	Article number:	Ratio			
		1:1	2:1	4:1	10:1
DM 400-01	114399	✓	✓		
DM 400-04	114400			✓	
DM 400-10	114401				✓

## Packaging:

Packed individually 1 units per master carton

## Matching MIXPAC™ cartridges (C-System and F-System)



400mL / 1:1  
PP/PA



400mL / 2:1  
PP/PA



400mL / 4:1  
PP/PBT



400mL / 10:1  
PP/PBT

## Other matching cartridges

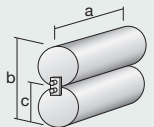

1:1	mm	inch
a	185	7.28
b	93	3.66
c	Ø 45	Ø 1.77

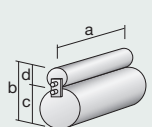

2:1	mm	inch
a	185	7.28
b	96	3.78
c	Ø 52	Ø 2.05
d	Ø 37	Ø 1.46

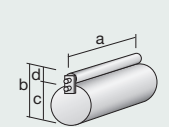

4:1	mm	inch
a	185	7.28
b	91	3.58
c	Ø 58	Ø 2.28
d	Ø 30	Ø 1.18

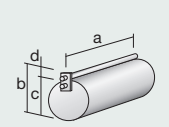

10:1	mm	inch
a	185	7.28
b	94	3.70
c	Ø 66	Ø 2.60
d	Ø 24	Ø 0.94

## Conversion kits

CK 400-01, CK 400-04, CK 400-10, See page 18.

## Matching accessories

All accessories are displayed on page 18.





# MIXPAC™ 2-Component Dispenser

## MIXPAC™ DP 200-70

A pneumatic operated dispenser for cartridges.

### Dispense Indicator

To quickly see how much material is remaining in the cartridge

### Support Tray

Cartridge snap fit  
Easy to exchange and replace

### Cartridge Release Button

Conveniently located to provide easiest cartridge ejection

### Trigger

Safety feature.  
Dispenser will not operate unless cartridge is installed

### Counter Balance Mount

To suspend dispenser

### Quick Exhaust

To relieve pressure and prevent oozing and dripping

### Release Button

Easily accessible with one hand

Regulator:  
adjust output force



### Product advantages

- Designed specifically for Mixpac C and F System Cartridges
- Cartridge snap fit
- One-hand-operation
- Integrated anti-drip feature

### Customer benefits

- Easy cartridge positioning and fixation
- Ergonomic
- High precision and dispensing accuracy
- Can easily be converted into all ratios with proper conversion kits.

### Applications



Bonding



Sealing



Repair

### Product by range



**Pneumatic Dispenser DP 200-70-01**

**Pneumatic Dispenser DP 200-70-04**

**Pneumatic Dispenser DP 200-70-10**

**Pneumatic Dispenser DP 400-85-01**

# The MIXPAC™ DP 200-70 - designed to provide reliable 2-component dispensing.

## Specifications

- Weight 1.66kg / 3.66lbs
- Length: 402mm / 15.8in
- Maximum Thrust: 2.2kN
- Tool material: cast aluminium and reinforced nylon
- Cartridge capacity: 200mL
- Cartridge ratio: 1:1/2:1/4:1/10:1
- Air inlet: G 1/4in
- Max operating pressure: 6.8 bar

## Dimensions

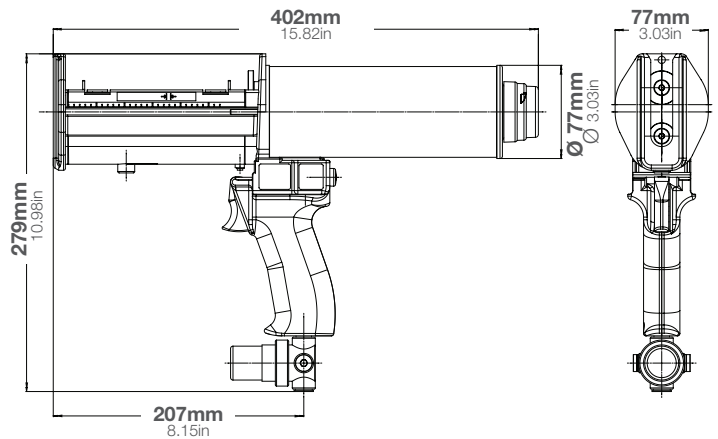

## Packaging:

Packed individually 1 units per master carton

Part number:	Article number:	Ratio			
		1:1	2:1	4:1	10:1
DP 200-70-01	114780	✓	✓		
DP 200-70-04	114425			✓	
DP 200-70-10	114535				✓

## Matching MIXPAC™ cartridges (C-System and F-System)

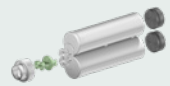

200mL / 1:1  
PP/PA



200mL / 2:1  
PP/PA



200mL / 4:1  
PP/PBT



200mL / 10:1  
PP/PBT

## Other matching cartridges

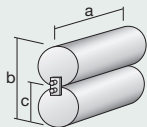

1:1	mm	inch
a	148	5.83
b	79	7.04
c	Ø 37	Ø 1.46

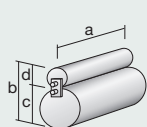

2:1	mm	inch
a	148	5.83
b	81	3.19
c	Ø 50	Ø 1.97
d	Ø 31	Ø 1.22

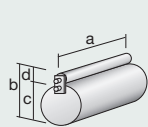

4:1	mm	inch
a	148	5.83
b	77	3.03
c	Ø 49	Ø 1.93
d	Ø 25	Ø 0.98

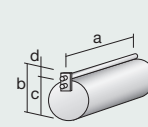

10:1	mm	inch
a	148	5.83
b	78	3.07
c	Ø 55	Ø 2.17
d	Ø 19	Ø 0.75

## Conversion kits

CK 200-70-01, CK 200-70-04, CK 200-70-10, See page 18.

## Matching accessories

All accessories are displayed on page 18.



# MIXPAC™ 2-Component Dispenser

## MIXPAC™ DP 400-85

A pneumatic operated dispenser for cartridges.

### Dispense Indicator

To quickly see how much material is remaining in the cartridge

### Support Tray

Cartridge snap fit  
Easy to exchange and replace

### Cartridge Release Button

Conveniently located to provide easiest cartridge ejection

### Trigger

Safety feature.  
Dispenser will not operate unless cartridge is installed

### Counter Balance Mount

To suspend dispenser

### Quick Exhaust

To relieve pressure and prevent oozing and dripping

### Release Button

Easily accessible with one hand

Regulator:  
adjust output force



### Product advantages

- Designed specifically for Mixpac C and F System Cartridges
- Cartridge snap fit
- One-hand-operation
- Integrated anti-drip feature

### Customer benefits

- Easy cartridge positioning and fixation
- Ergonomic
- High precision and dispensing accuracy
- Can easily be converted into all ratios with proper conversion kits.

### Applications



Bonding



Sealing



Repair

### Product by range





# The MIXPAC™ DP 400-85 - designed to provide reliable 2-component dispensing.

## Specifications

- Weight 2.18kg / 4.81lbs
- Length: 402mm / 15.8in
- Maximum Thrust: 3.2kN
- Tool material: cast aluminium and reinforced nylon
- Cartridge capacity: 400mL
- Cartridge ratio: 1:1/2:1/4:1/10:1
- Air inlet: G 1/4in
- Max operating pressure: 6.8 bar

## Dimensions

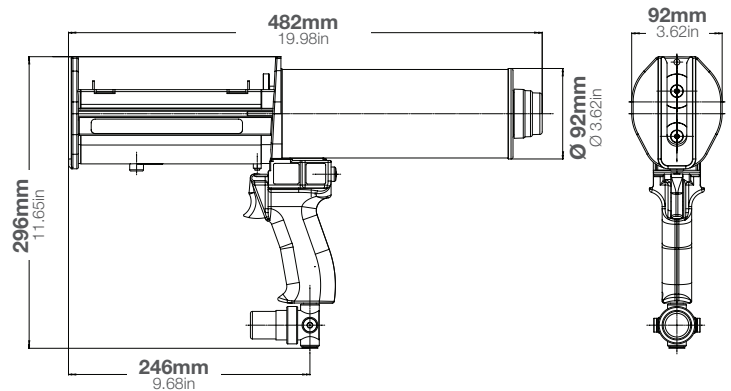

Part number:	Article number:	Ratio			
		1:1	2:1	4:1	10:1
DP 400-85-01	114781	✓	✓		
DP 400-85-04	114782			✓	
DP 400-85-10	114783				✓

## Packaging:

Packed individually 1 units per master carton

## Matching MIXPAC™ cartridges (C-System and F-System)



400mL / 1:1  
PP/PA



400mL / 2:1  
PP/PA



400mL / 4:1  
PP/PBT



400mL / 10:1  
PP/PBT

## Other matching cartridges

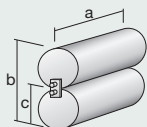

1:1	mm	inch
a	185	7.28
b	93	3.66
c	Ø 45	Ø 1.77

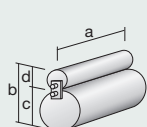

2:1	mm	inch
a	185	7.28
b	96	3.78
c	Ø 52	Ø 2.05
d	Ø 37	Ø 1.46

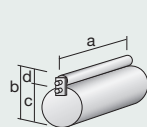

4:1	mm	inch
a	185	7.28
b	91	3.58
c	Ø 58	Ø 2.28
d	Ø 30	Ø 1.18

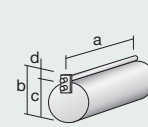

10:1	mm	inch
a	185	7.28
b	94	3.70
c	Ø 66	Ø 2.60
d	Ø 24	Ø 0.94

## Conversion kits

CK 400-85-01, CK 400-85-04, CK 400-85-10, See page 18.

## Matching accessories

All accessories are displayed on page 18.



# MIXPAC™ 2-Component Dispenser

## MIXPAC™ DP 400-100

A pneumatic operated dispenser for cartridges.

### Dispense Indicator

To quickly see how much material is remaining in the cartridge

### Support Tray

Cartridge snap fit  
Easy to exchange and replace

### Cartridge Release Button

Conveniently located to provide easiest cartridge ejection

### Trigger

Safety feature.  
Dispenser will not operate unless cartridge is installed

### Counter Balance Mount

To suspend cartridge

### Quick Exhaust

To relieve pressure and prevent oozing and dripping

### Release Button

Easily accessible with one hand

Regulator:  
adjust output force



### Product advantages

- Designed specifically for Mixpac C and F System Cartridges
- Cartridge snap fit
- One-hand-operation
- Integrated anti-drip feature

### Customer benefits

- Easy cartridge positioning and fixation
- Ergonomic
- High precision and dispensing accuracy
- Can easily be converted into all ratios with proper conversion kits.

### Applications



Bonding



Sealing



Repair

### Product by range



# The MIXPAC™ DP 400-100 - designed to provide reliable 2-component dispensing.

## Specifications

- Weight 2.41kg / 5.31lbs
- Length: 487mm / 19.2in
- Maximum Thrust: 4.5kN
- Tool material: cast aluminium and reinforced nylon
- Cartridge capacity: 400mL
- Cartridge ratio: 1:1/2:1/4:1/10:1
- Air inlet: G 1/4in
- Max operating pressure: 6.8 bar

## Dimensions

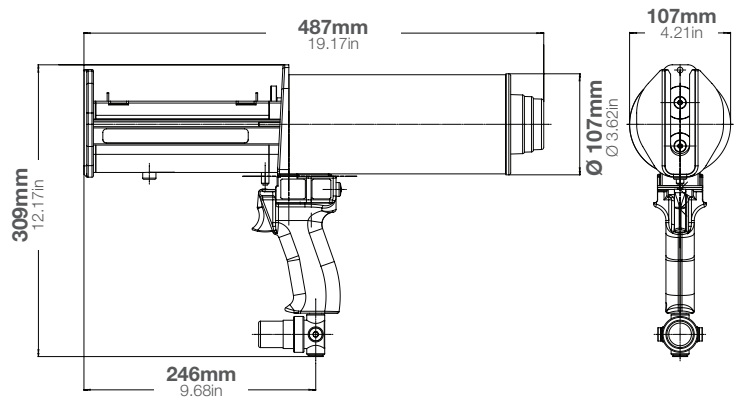

Part number:	Article number:	Ratio			
		1:1	2:1	4:1	10:1
DP 400-100-01	114466	✓	✓		
DP 400-100-04	114559			✓	
DP 400-100-10	114465				✓

## Packaging:

Packed individually 1 units per master carton

## Matching MIXPAC™ cartridges (C-System and F-System)

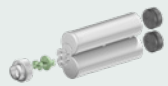

400mL / 1:1  
PP/PA



400mL / 2:1  
PP/PA



400mL / 4:1  
PP/PBT



400mL / 10:1  
PP/PBT

## Other matching cartridges

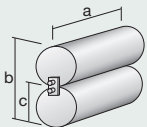

1:1	mm	inch
a	185	7.28
b	93	3.66
c	Ø 45	Ø 1.77

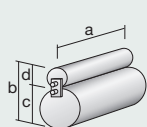

2:1	mm	inch
a	185	7.28
b	96	3.78
c	Ø 52	Ø 2.05
d	Ø 37	Ø 1.46

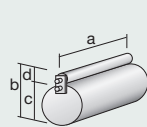

4:1	mm	inch
a	185	7.28
b	91	3.58
c	Ø 58	Ø 2.28
d	Ø 30	Ø 1.18

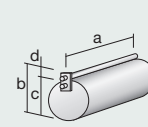

10:1	mm	inch
a	185	7.28
b	94	3.70
c	Ø 66	Ø 2.60
d	Ø 24	Ø 0.94

## Conversion kits

CK 400-100-01, CK 400-100-04, CK 400-100-10, See page 18.

## Matching accessories

All accessories are displayed on page 18.



# MIXPAC™ Accessories and Spare Parts for Dispenser

System	ID	Article	Type
<b>DS</b> 50/75mL	103160	PLS 053-01	Plunger
	113018	PLS 051-04	Plunger
	100385	PLS 051-10	Plunger
	113559	PLS 077-01	Plunger
	115587	PLS 075-10	Plunger
	113719	PRS 050-01-02	Retention Clip
	116564	PRS 050-04-10A	Retention Clip
<b>DMA / DMB</b> 50/75mL	109018	PLA 050-01	Plunger
	109020	PLA 050-04	Plunger
	103114	PLA 050-10	Plunger
	109193	PLA 075-01	Plunger
	128083	PLB 50-04	Plunger
	128084	PLB 50-10	Plunger
	103213	PR 050-01-02	Retention Clip
	103214	PR 050-04-10	Retention Clip
<b>DM 200</b> 200mL	114572	CK 200-01	Cartridge Tray
	114573	CK 200-04	Cartridge Tray
	114574	CK 200-10	Cartridge Tray
	114542	PL 200-01	Plunger
	114543	PL 200-10	Plunger
<b>DM 400</b> 400mL	114485	CK 400-01	Conversion Kit
	114486	CK 400-04	Conversion Kit
	114407	CK 400-10	Conversion Kit
<b>DP 200-70</b> 200mL	114402	CK 200-70-01	Conversion Kit
	114403	CK 200-70-04	Conversion Kit
	114404	CK 200-70-10	Conversion Kit
<b>DP 400-85</b> 400mL	114408	CK 400-85-01	Conversion Kit
	114409	CK 400-85-04	Conversion Kit
	114410	CK 400-85-10	Conversion Kit
<b>DP 400-100</b> 400mL	114685	CK 400-100-01	Conversion Kit
	114686	CK 400-100-04	Conversion Kit
	114687	CK 400-100-10	Conversion Kit



## Innovation in Application

### **Headquarters / Europe**

Sulzer Mixpac Ltd  
Ruetistrasse 7  
9469 Haag, Switzerland  
phone +41 81 772 20 00  
fax +41 81 772 20 01  
mixpac@sulzer.com  
www.sulzer.com

### **USA, South America, Canada and Mexico**

Sulzer Mixpac USA Inc.  
8 Willow St.  
Salem, NH 03079, USA  
phone +1 603 893 2727  
info@SulzerMixpacUSA.com  
www.sulzer.com

### **UK and Ireland**

Sulzer Mixpac (UK) Ltd.  
1 Tealgate, Charnham Park, Hungerford  
Berkshire, RG17 0YT, United Kingdom  
phone: +44 (0)1488 647 800  
coxsales@sulzer.com  
www.coxdispensers.com

### **Asia Pacific**

Sulzer Mixpac China  
68 Bei Dou Lu, Minhang  
Shanghai 200245, China  
phone +86 21 6430 68 68  
mixpac@sulzer.com  
www.sulzer.com